



ISO16028型 系列号: A8013

特点: 特别适用于工程机械, 善于处理峰值压力, 高品质, 带安全锁, 平面式, 钢珠锁定, 碳钢镀锌。

平面式优点: 连接时夹气最少, 避免泥土灰尘的侵入造成油路污染; 拆断时无泄漏, 避免油液、油压损失和污染环境。

对外连接: 内螺纹: BSP (G), NPT, UNF;

外螺纹: M (24°卡套式及隔板式)。

规格: 1/8"、1/4"、3/8"、1/2"、3/4"、1"、1-1/4"、1-1/2"。

接合状态下最大工作压力: 420bar至270bar。

国际标准: ISO16028;

其中ISO10可按NFPA 3.20.15(HTMA)互换。

密封材质: 标准供货丁腈橡胶NBR。其他可按需提供。

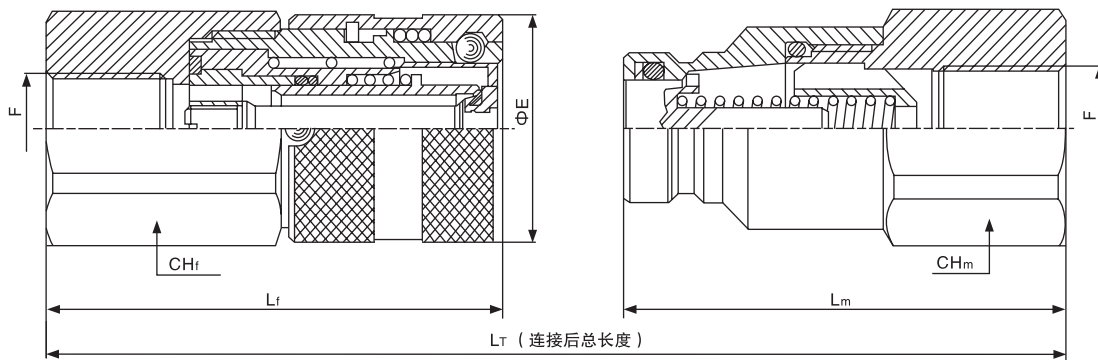

ISO	CH _f	CH _m	ΦE	L _T	L _f	L _m	F	母接头(F)订货号	公接头(M)订货号	组合订货号
5.0	19	17	20	68.5	40	36.3	G1/8	A4-F-G1/8	A4-M-G1/8	A4-FM-G1/8
							1/8NPT	A4-F-1/8NPT	A4-M-1/8NPT	A4-FM-1/8NPT
6.3	27	22	28	90.2	53.1	47.9	G1/4	A7-F-G1/4	A7-M-G1/4	A7-FM-G1/4
							1/4NPT	A7-F-1/4NPT	A7-M-1/4NPT	A7-FM-1/4NPT
10.0	30	27	32	108.8	64.8	60	G3/8	A9-F-G3/8	A9-M-G3/8	A9-FM-G3/8
							3/8NPT	A9-F-3/8NPT	A9-M-3/8NPT	A9-FM-3/8NPT
10.0	30	27	32	116.3	69.8	62.5	G1/2	A9-F-G1/2	A9-M-G1/2	A9-FM-G1/2
							1/2NPT	A9-F-1/2NPT	A9-M-1/2NPT	A9-FM-1/2NPT
12.5	36	36	38	127.6	76.8	68	G1/2	A13-F-G1/2	A13-M-G1/2	A13-FM-G1/2
							1/2NPT	A13-F-1/2NPT	A13-M-1/2NPT	A13-FM-1/2NPT
12.5	36	36	38	137.1	83.8	70.5	G3/4	A13-F-G3/4	A13-M-G3/4	A13-FM-G3/4
							3/4NPT	A13-F-3/4NPT	A13-M-3/4NPT	A13-FM-3/4NPT
16.0	41	36	42	139.5	84	73	G3/4	A15-F-G3/4	A15-M-G3/4	A15-FM-G3/4
							3/4NPT	A15-F-3/4NPT	A15-M-3/4NPT	A15-FM-3/4NPT
19.0	46	46	48	158.7	96.8	83.7	G3/4	A17-F-G3/4	A17-M-G3/4	A17-FM-G3/4
							3/4NPT	A17-F-3/4NPT	A17-M-3/4NPT	A17-FM-3/4NPT
19.0	46	48	48	160.7	98.8	83.7	G1	A17-F-G1	A17-M-G1	A17-FM-G1
							1NPT	A17-F-1NPT	A17-M-1NPT	A17-FM-1NPT
25.0	55	55	55	178.6	104.8	96.8	G1	A21-F-G1	A21-M-G1	A21-FM-G1
							1NPT	A21-F-1NPT	A21-M-1NPT	A21-FM-1NPT

ISO	CH _f	CH _m	ΦE	L _T	L _f	L _m	F	母接头(F)订货号	公接头(M)订货号	组合订货号
25.0	55	55	55	172.8	105.8	90	G1-1/4	A21-F- G1-1/4	A21-M- G1-1/4	A21-FM- G1-1/4
							1-1/4NPT	A21-F-1-1/4NPT	A21-M-1-1/4NPT	A21-FM-1-1/4NPT
28.5	55	55	65	197.1	120.1	100	G1	A25-F- G1	A25-M- G1	A25-FM- G1
				207.1	125.1	105	1NPT	A25-F-1NPT	A25-M-1NPT	A25-FM-1NPT
28.5	55	55	65	207.1	125.1	105	G1-1/4	A25-F- G1-1/4	A25-M- G1-1/4	A25-FM- G1-1/4
							1-1/4NPT	A25-F-1-1/4NPT	A25-M-1-1/4NPT	A25-FM-1-1/4NPT
31.5	65	65	80	215.1	132.4	111.1	G1-1/2	A30-F- G1-1/2	A30-M- G1-1/2	A30-FM- G1-1/2
							1-1/2NPT	A30-F-1-1/2NPT	A30-M-1-1/2NPT	A30-FM-1-1/2NPT

压降流量曲线图 (ΔP-Q)

测试条件

标准: ISO 7241-2

流体: 油 ISO VG32

温度: 40℃

粘度: 28.8~35.2mm²/s

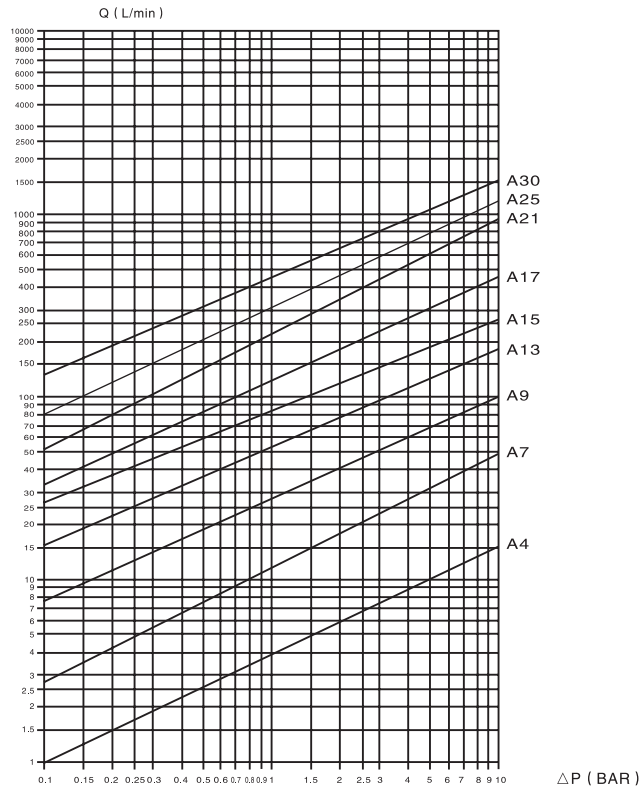

ISO16028型A8013系列技术参数

ISO	DN	接合状态下 最大工作压力(bar)	公称流量(L/min)	最大流量(L/min)
5.0	4.0	420	3	8
6.3	7.0	420	12	24
10.0	9.0	350	23	46
12.5	13.0	330	45	90
16.0	15.0	330	74	148
19.0	17.0	330	100	200
25	21.0	300	189	378
31.5	30.0	270	288	576

* 可提供防尘帽。