

FA/FK 方法兰系列(PN10-64/series 0)

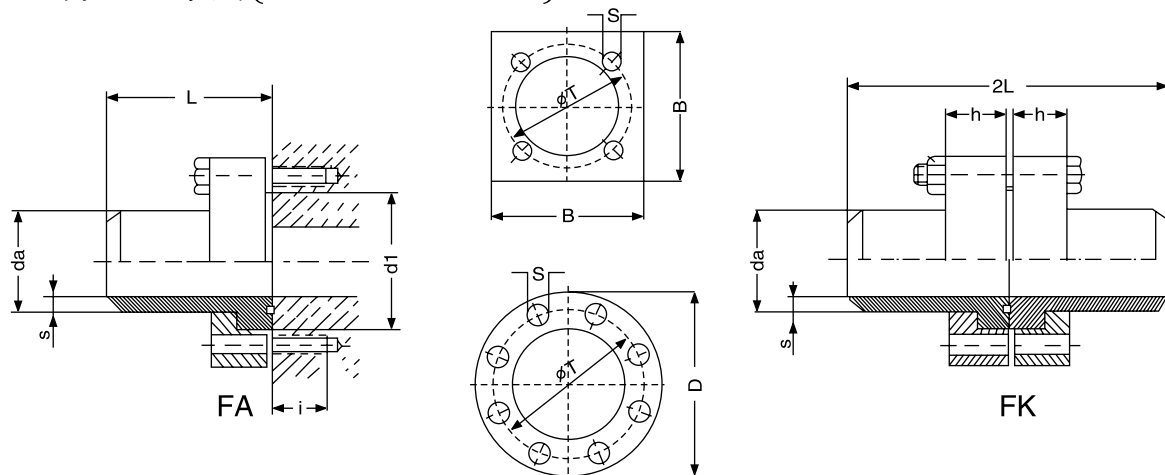

标准订货:

- 方形法兰1只
- 带○槽焊接接管1只
- 形密封圈1只
- 12.9级高强度螺栓4只(带弹垫)

标准订货:

- 方形法兰2只
- 焊接接管1对
- 形圈1只
- 12.9级高强度螺栓4套(带弹垫及螺母)

daxs为所连接钢管规格，也可根据用户要求提供

编号 type	尺寸参数 dimension										重量 Wt.Kg
	daxs	B	D	h	T	d1	S	L	配用螺栓	○形圈	
FA FK 32-0	42.4x2.6	80	-	24	72	55	12.50	64	M12x40 M12x70	37.7x3.55	1.40 2.65
FA FK 40-0	48.3x2.6	90	-	29	80	60	17.00	68	M16x50 M16x80	47.2x3.55	2.00 3.90
FA FK 50-0	60.3x2.9 60.3x4.5	100	-	38	98	76	17.00	80	M16x50 M16x100	58x3.55	3.00 5.90
FA FK 65-0	76.1x2.9 76.1x3.6	120	-	47	118	92	21.00	98	M20x70 M20x120	74x5.33	5.20 9.90
FA FK 80-0	88.9x3.2 88.9x4	150	-	48	145	110	25.00	109	M24x75 M24x130	88.6x5.7	9.00 17.45
FA FK 90-0	101.6x7.1	180	-	59	175	135	32.00	135	M30x90 M30x150	98.6x5.7	15.50 30.50
FA FK 100-0	114.3x3.6 114.3x7.1	180	-	59	175	135	32.00	135	M30x90 M30x150	108.6x5.7	15.50 30.50
FA FK 125-0	139.7x8.0 139.7x10	-	245	69	200	168	25.00	150	M24x100 M24x170	128.6x5.7	27.00 53.60
FA FK 150-0	168.3x6 168.3x10	-	300	79	245	205	31.50	190	M30x110 M30x200	170x7 160x7	47.00 93.00

Example示例:

碳钢制:

- FA 50-0/60.3x2.9, FK 50-0/60.3x2.9
- FAMG 50-0 (闷盖式)
- FKG 50-0/50-0/60.3x2.9 (带闷盖式)

不锈钢制:

- FA -X-50-0/60.3x2.9, FK 50-0/60.3x2.9
- FAMG-X-50-0
- FK-X-50-0/60.3x2.9

FA/FK 方法兰系列(PN160/series 2)

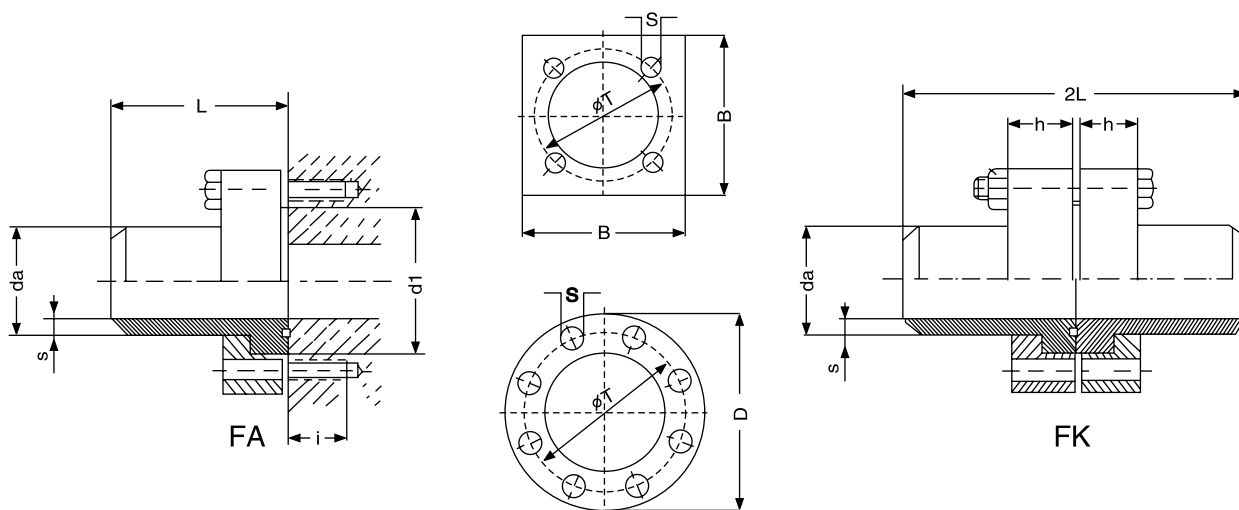

标准订货:

- 方形法兰1只
- 带○槽焊接接管1只
- 形圈1只
- 12.9级高强度螺栓4只(带弹垫)

标准订货:

- 方形法兰2只
- 焊接接管1对
- 形圈1只
- 12.9级高强度螺栓4只(带弹垫及螺母)

daxs为所连接钢管规格, 也可根据用户要求提供

编号 type	尺寸参数 dimension										重量 Kg
	daxs	B	D	h	T	d1	S	L	配用螺栓	○形圈	
FA 12-2 FK	16x2	50	-	19	44	28	10.50	40	M10x35 M10x55	17.1x3.55	0.40 0.80
FA 16-2 FK	20x2.5	60	-	19	54	38	10.50	46	M10x35 M10x55	18.7x3.55	0.65 1.20
FA 20-2 FK	25x2.5 25x3	60	-	19	54	38	10.50	46	M10x35 M10x55	25x3.55	0.65 1.20
FA 25-2 FK	30x3 30x4	70	-	19	64	46	12.50	52	M12x35 M12x60	32.9x3.55	0.90 1.70
FA 32-2 FK	38x4.0 38x5.0	80	-	24	72	55	12.50	64	M12x40 M12x70	32.9x3.55	1.40 2.65
FA 40-2 FK	48.3x4.0 48.3x5.0	90	-	29	80	60	17.00	68	M16x50 M16x80	47.2x3.55	2.00 3.90
FA 50-2 FK	60.3x5.0 60.3x6.3	100	-	38	98	76	17.00	80	M16x50 M16x100	53.3x5.33	3.00 5.90
FA 65-2 FK	76.1x6.3 76.1x7.1	120	-	47	118	92	21.00	98	M20x70 M20x120	69x5.33	5.20 9.90
FA 80-2 FK	101.6x8.8 101.6x10	180	-	59	175	135	32.00	135	M30x90 M30x150	88.6x5.7	15.50 30.50
FA 100-2 FK	114.3x10 114.3x11	180	-	59	175	135	32.00	135	M30x90 M30x150	103.6x5.7	15.50 30.50
FA 125-2 FK	152.4x12.5 152.4x16	-	245	69	200	168	25.00	150	M24x100 M24x170	128.6x5.7	27.00 53.60
FA 150-2 FK	177.8x16.8 177.8x17.5	-	300	79	245	205	31.50	190	M30x110 M30x200	160x7	47.00 93.00

FA/FK 方法兰系列(PN250/series 3)

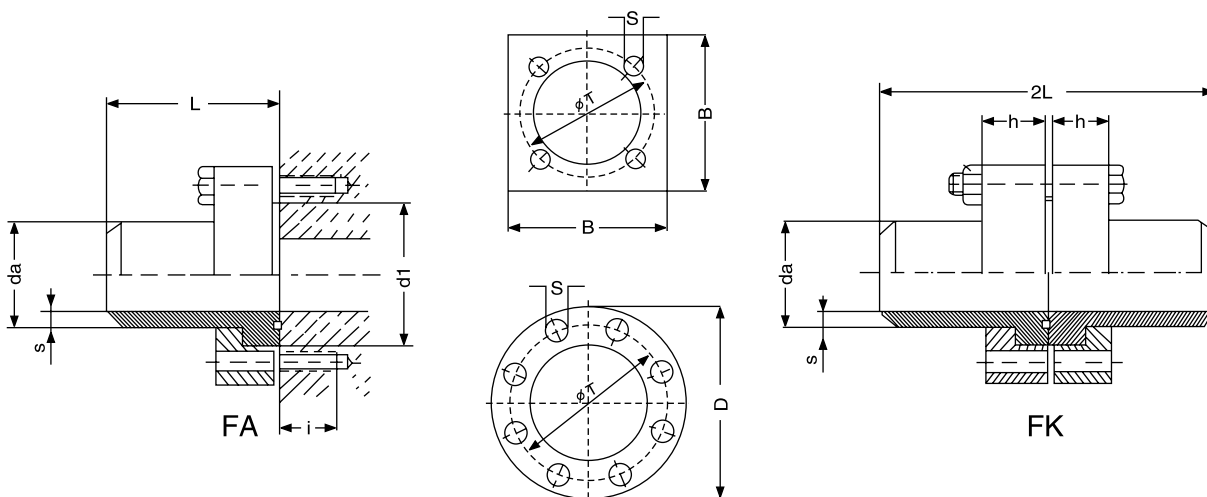

标准订货:

- 方形法兰1只
- 带○槽焊接接管1只
- 形圈1只
- 12.9级高强度螺栓4只(带弹垫)

标准订货:

- 方方法兰2只
- 焊接接管1对
- 形圈1只
- 12.9级高强度螺栓4只(带弹垫及螺母)

daxs为所连接钢管规格, 也可根据用户要求提供

编号 type	尺寸参数 dimension										重量 Wt.Kg
	daxs	B	D	h	T	d1	S	L	配用螺栓	○形圈	
FA 10-3 FK	16x2 16x2.6	50	-	19	44	28	10.50	40	M10x35 M10x55	17.1x3.55	0.40 0.80
FA 12-3 FK	20x2.5 20x2.9	60	-	19	54	38	10.50	46	M10x35 M10x55	18.7x3.55	0.65 1.20
FA 16-3 FK	21.3x2.6 21.3x3.6	60	-	19	54	38	10.50	46	M10x35 M10x55	18.7x3.55	0.65 1.20
FA 20-3 FK	26.9x3.6	70	-	19	64	46	12.50	52	M12x35 M12x60	25x3.55	0.90 1.70
FA 25-3 FK	33.7x4.5	80	-	24	72	55	12.50	64	M12x40 M12x70	37.7x3.55	1.40 2.65
FA 32-3 FK	42.4x5.5	90	-	29	80	60	17.00	68	M16x50 M16x80	37.7x3.55	2.00 3.90
FA 40-3 FK	60.3x8	100	-	38	98	76	17.00	80	M16x50 M16x100	53.3x5.33	3.00 5.90
FA 50-3 FK	76.1x10	120	-	47	118	92	21.00	98	M20x70 M20x120	61.5x5.33	5.20 9.90
FA 65-3 FK	88.9x11	150	-	48	145	110	25.50	135	M24x75 M24x130	78.6x5.7	9.00 17.50
FA 80-3 FK	101.6x12.5 101.6x14.2	180	-	59	175	135	32.00	135	M30x90 M30x150	88.6x5.7	15.50 30.50
FA 100-3 FK	139.7x17.5 139.7x20	-	245	69	200	168	25.00	150	M24x100 M24x170	113.6x5.7	27.00 53.60
FA 125-3 FK	168.3x20 168.3x22	-	300	79	245	205	31.50	190	M30x110 M30x200	148x7	47.00 93.00

FA/FK 方法兰系列(PN320/series 4)

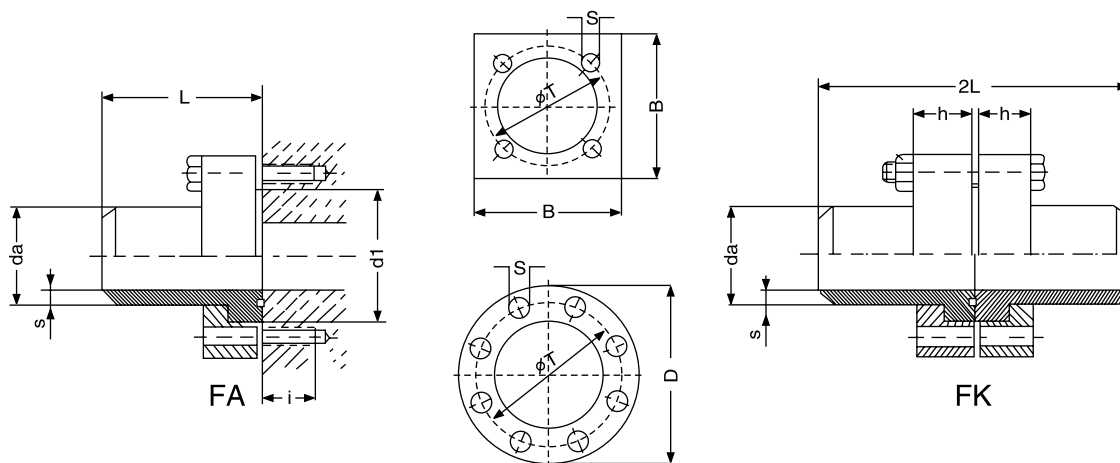

标准订货:

- 方形法兰1只
- 带○槽焊接接管1只
- 形圈1只
- 12.9级高强度螺栓4只(带弹垫)

标准订货:

- 方形法兰2只
- 焊接接管1对
- 形圈1只
- 12.9级高强度螺栓4只(带弹垫及螺母)

daxs为所连接钢管规格, 也可根据用户要求提供

编号 type	尺寸参数 dimension										重量 Wt.Kg
	daxs	B	D	h	T	d1	S	L	配用螺栓	○形圈	
FA FK 10-4	17.2x3.6	50	-	19	44	28	10.50	40	M10x35 M10x55	18.7x3.55	0.40 0.80
FA FK 12-4	20x4 21.3x3.6	60	-	19	54	38	10.50	46	M10x35 M10x55	18.7x3.55	0.65 1.20
FA FK 16-4	26.9x4.5	60	-	19	54	38	10.50	46	M10x35 M10x55	25x3.55	0.65 1.20
FA FK 20-4	33.7x5.6	70	-	19	64	46	12.50	52	M12x35 M12x60	32.9x3.55	0.90 1.70
FA FK 25-4	42.7x7.1	80	-	24	72	55	12.50	64	M12x40 M12x70	32.9x3.55	1.40 2.65
FA FK 32-4	48.3x8	90	-	29	80	60	17.00	68	M16x50 M16x80	40x3.55	2.00 3.90
FA FK 40-4	60.3x10	100	-	38	98	76	17.00	80	M16x50 M16x100	53.3x5.33	3.00 5.90
FA FK 50-4	76.1x12.5	120	-	47	118	92	21.00	98	M20x70 M20x120	61.5x5.33	5.20 9.90
FA FK 65-4	88.9x14.2	150	-	48	145	110	25.50	109	M24x75 M24x130	78.6x5.7	9.00 17.50
FA FK 70-4	101.6x16	180	-	59	175	135	32.00	135	M30x90 M30x150	88.6x5.7	15.50 30.50
FA FK 80-4	114.3x17.5 114.3x20	180	-	59	175	135	32.00	135	M30x90 M30x150	88.6x5.7	15.50 30.50
FA FK 100-4	139.7x22.2 152.5x28	-	245	69	200	168	25.00	150	M24x100 M24x170	113.6x5.7	27.00 53.60
FA FK 125-4	177.8x30	-	300	79	245	205	31.50	190	M30x110 M30x200	148x7	47.00 93.00

FA/FK 方法兰系列(PN400/series 5)

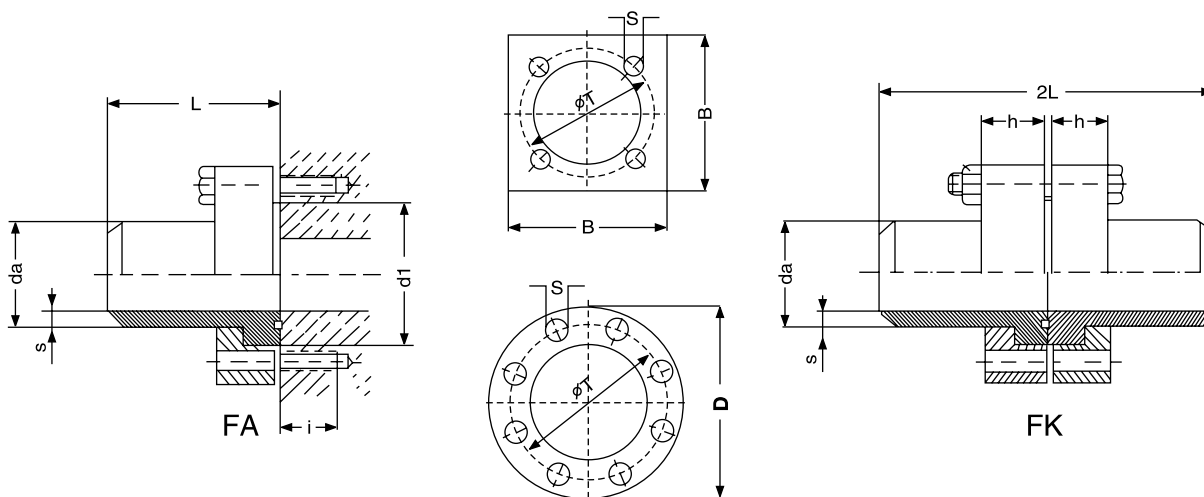

标准订货:

- 方形法兰1只
- 带○槽焊接接管1只
- 形圈1只
- 12.9级高强度螺栓4只(带弹垫)

标准订货:

- 方形法兰2只
- 焊接接管1对
- 形圈1只
- 12.9级高强度螺栓4只(带弹垫及螺母)

daxs为所连接钢管规格, 也可根据用户要求提供

编号 type	尺寸参数 dimension										重量 Wt.Kg
	daxs	B	D	h	T	d1	S	L	配用螺栓	○形圈	
FA FK 32-5	48.3x8.8	100	-	38	98	76	17.00	80	M16x50 M16x100	53.3x5.33	3.00 5.90
FA FK 40-5	60.0x11	120	-	44	118	92	21.00	98	M20x70 M20x120	61.5x5.33	5.20 9.90
FA FK 50-5	76.1x14.2	150	-	48	145	110	25.00	109	M24x75 M24x130	74x5.7	9.50 18.35
FA FK 65-5	101.6x20	180	-	58	175	135	32.00	135	M30x90 M30x150	88.6x5.7	15.50 30.50
FA FK 80-5	133.7x25	-	245	68	200	172	25.00	150	M24x100 M24x170	115.0x5.7	27.00 53.60
FA FK 100-5	152.4x30	-	300	78	245	205	31.50	190	M30x110 M30x200	148x7	47.00 93.00

Example示例:

碳钢制:

- FA 50-5/76.1x14.2, FK 50-5/76.1x14.2
- FAMG 50-5 (闷盖式)
- FKG 50-5/76.1x14.2 (带闷盖式)

不锈钢制:

- FA-X-50-5/76.1x14.2, FK-X 50-5/76.1x14.2
- FAMG-X-50-5 (闷盖式)
- FK-X-50-5/76.1x14.2 (带闷盖式)